

BP21

EN

OPERATING MANUAL
PYROMETER



Table of contents

Notes regarding the operating manual..... 2

Safety 2

Information about the device..... 4

Transport and storage..... 6

Operation 7

Maintenance and repair 9

Errors and faults..... 9

Disposal 9

Notes regarding the operating manual

Symbols

 **Warning of electrical voltage**
This symbol indicates dangers to the life and health of persons due to electrical voltage.

 **Warning of laser radiation**
This symbol indicates dangers to the health of persons due to laser radiation.

 **Warning**
This signal word indicates a hazard with an average risk level which, if not avoided, can result in serious injury or death.

 **Caution**
This signal word indicates a hazard with a low risk level which, if not avoided, can result in minor or moderate injury.

Note
This signal word indicates important information (e.g. material damage), but does not indicate hazards.

 **Info**
Information marked with this symbol helps you to carry out your tasks quickly and safely.

 **Follow the manual**
Information marked with this symbol indicates that the operating manual must be observed.

You can download the current version of the operating manual and the EU declaration of conformity via the following link:



BP21



<https://hub.trotec.com/?id=44511>

Safety

Read this manual carefully before starting or using the device. Always store the manual in the immediate vicinity of the device or its site of use!

-  **Warning**
Read all safety warnings and all instructions. Failure to follow the warnings and instructions may result in electric shock, fire and / or serious injury.
Save all warnings and instructions for future reference.
This appliance can be used by children aged from 8 years and above and persons with reduced physical, sensory or mental capabilities or lack of experience and knowledge if they have been given supervision or instruction concerning use of the appliance in a safe way and understand the hazards involved.
Children shall not play with the appliance. Cleaning and user maintenance shall not be made by children without supervision.
- Do not use the device in potentially explosive rooms.
 - Do not use the device in aggressive atmosphere.
 - Do not immerse the device in water. Do not allow liquids to penetrate into the device.
 - The device may only be used in dry surroundings and must not be used in the rain or at a relative humidity exceeding the operating conditions.
 - Protect the device from permanent direct sunlight.
 - Do not expose the device to strong vibrations.
 - Do not remove any safety signs, stickers or labels from the device. Keep all safety signs, stickers and labels in legible condition.
 - Do not open the device.
 - Avoid looking directly into the laser beam.
 - Never point the laser beam at people or animals.
 - Observe the storage and operating conditions as given in the Technical data chapter.

Intended use

This device is exclusively intended for measuring temperature by means of an infrared sensor in the measuring range specified in the technical data. People who use this device must have read and understood the operating manual, especially the Safety chapter.

To use the device for its intended use, only use accessories and spare parts which have been approved by Trotec.

Improper use

The device must not be pointed at people. Do not use the device in potentially explosive atmospheres, for measurements in liquids or at live parts. Trotec accepts no liability for damages resulting from improper use. In such a case, any warranty claims will be voided. Any unauthorised modifications, alterations or structural changes to the device are forbidden.

Personnel qualifications

People who use this device must:

- be aware of the dangers that occur when working with laser measuring devices.
- have read and understood the operating manual, especially the Safety chapter.

Residual risks



Warning of laser radiation

**Laser class 2, P max.: < 1 mW, λ: 400-700 nm,
EN 60825-1:2014**

Do not look directly into the laser beam or the opening from which it emerges.

Never point the laser beam at people, animals or reflective surfaces. Even brief eye contact can lead to eye damage.

Examining the laser output aperture by use of optical instruments (e.g. magnifying glass, magnifiers and the like) entails the risk of eye damage.

When working with a laser of class 2, observe the national regulations on wearing eye protection.



Warning

Risk of suffocation!

Do not leave the packaging lying around. Children may use it as a dangerous toy.



Warning

The device is not a toy and does not belong in the hands of children.



Warning

Dangers can occur at the device when it is used by untrained people in an unprofessional or improper way! Observe the personnel qualifications!



Caution

Keep a sufficient distance from heat sources.

Note

To prevent damages to the device, do not expose it to extreme temperatures, extreme humidity or moisture.

Note

Do not use abrasive cleaners or solvents to clean the device.

Information about the device

Device description

The pyrometer BP21 uses an infrared sensor to measure surface temperatures without contact. An integrated dual laser pointer can be switched on for the precise determination of the measuring spot diameter.

In addition, you can set the degree of emission of the material to be measured which will result in a more precise measurement result.

The device further features an alarm function. When exceeding or falling below the specified values, the device emits an acoustic signal.

Moreover, the device can indicate either the highest or lowest value of the measurement.

The display can be illuminated as needed. An automatic switch-off function saves the battery when not in use.

Measuring principle

The device measures the temperature by means of an infrared sensor. Important factors playing a role in the temperature measurement are the measuring spot diameter and the degree of emission.

Measuring spot

Observe the ratio of the distance (D) to the measuring spot diameter (S). The larger the distance to the object, the larger the measuring spot diameter and hence, the less precise the measured result, for the device calculates an average temperature from all the temperatures in the measuring spot.

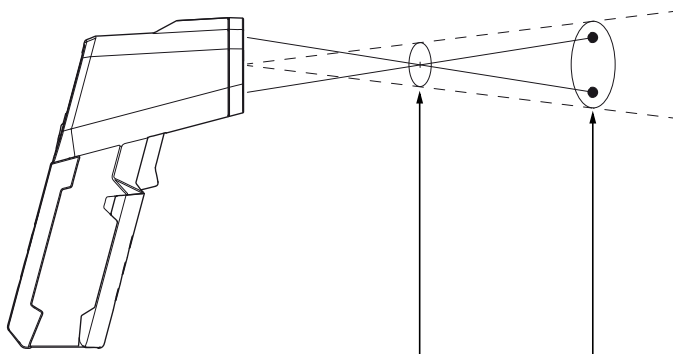

Spot	12.5 mm	100 mm
Distance	150 mm	1200 mm
D:S = 12:1	 	Laser Infrared

Degree of emission

The degree of emission is used to describe the energy radiation characteristics of a material.

Most organic materials have an emissivity of 0.95. Metals or shiny materials come with a much lower value.

A material's emissivity depends on various factors, e.g. on

- Material composition
- Surface condition
- Temperature

The emissivity can range between 0.1 and 1 (in theory).

The following rule of thumb can be assumed:

- When a material is rather dark and its surface texture matt, it probably has a high emissivity.
- The brighter and smoother the surface of a material, the lower will be its emissivity, presumably.
- The higher the degree of emission of the surface to be measured, the better it is suited for non-contact temperature measurement by use of a pyrometer or thermal imaging camera, since falsifying temperature reflections become negligible.

Nevertheless, entering a degree of emission as appropriate as possible is indispensable for a precise measurement.

Material	Degree of emission
Aluminium, roughened	0.1 to 0.3
Aluminium, alloy A3003, oxidized	0.3
Aluminium, oxidized	0.2 to 0.4
Asbestos	0.92 to 0.95
Tarmac	0.92 to 0.95
Basalt	0.7
Concrete	0.92 to 0.95
Bitumen	0.98 to 1.00
Lead, oxidized	0.2 to 0.6
Lead, rough	0.4
Roofing felt	0.95
Ice	0.98
Iron (forged), blunt	0.9
Iron, oxidized	0.5 to 0.9
Iron, rusted	0.5 to 0.7
Enamel varnish, black	0.95
Earth	0.92 to 0.96
Paint (not alkaline)	0.90 to 0.95
Paint (non-metal)	0.95
Gypsum	0.60 to 0.95
Glass, pane	0.85 to 0.95
Rubber	0.92 to 0.95

Material	Degree of emission
Cast iron, molten	0.2 to 0.3
Cast iron, not oxidized	0.2
Skin	0.98
Haynes alloy	0.3 to 0.8
Radiator enamel	0.95
Timber (natural)	0.90 to 0.95
Inconel, electro-polished	0.15
Inconel, oxidized	0.70 to 0.95
Inconel, sand-blasted	0.3 to 0.6
Limestone	0.95 to 0.98
Carborundum	0.9
Ceramics	0.88 to 0.95
Gravel	0.95
Carbon, graphite	0.70 to 0.85
Carbon, not oxidized	0.8 to 0.9
Plastic, non-transparent	0.95
Copper, oxidized	0.4 to 0.8
Varnish	0.80 to 0.95
Marble	0.90 to 0.95
Brass, highly polished	0.3
Brass, oxidized	0.5
Molybdenum, oxidized	0.2 to 0.6
Nickel, oxidized	0.2 to 0.5
Paper (any colour)	0.9
Plastic	0.85 to 0.95
Plaster	0.90 to 0.95
Sand	0.9
Snow	0.9
Steel, heavy plate	0.4 to 0.6
Steel, cold-rolled	0.7 to 0.9
Steel, oxidized	0.7 to 0.9
Steel, polished sheet metal	0.1
Steel, stainless	0.1 to 0.8
Cloth	0.95
Wallpaper (non-metal)	0.95
Textiles (non-metal)	0.95
Titanium, oxidized	0.5 to 0.6
Clay	0.90 to 0.95
Water	0.93
Cement	0.90 to 0.96
Brick (rough)	0.90 to 0.95
Zinc, oxidized	0.1

Device depiction

Device depiction

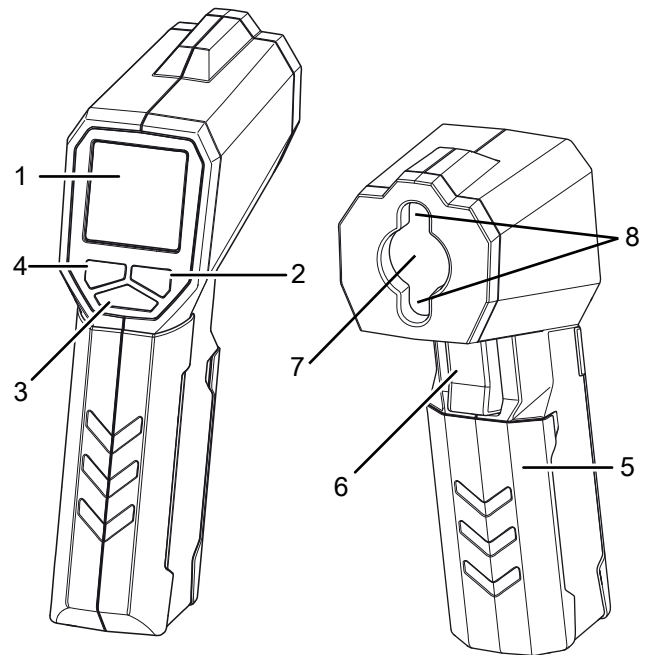

No.	Designation
1	Display
2	Lamp button
3	MODE button
4	Laser button
5	Battery compartment with cover
6	Measurement button
7	Infrared sensor
8	Dual laser pointer

Display

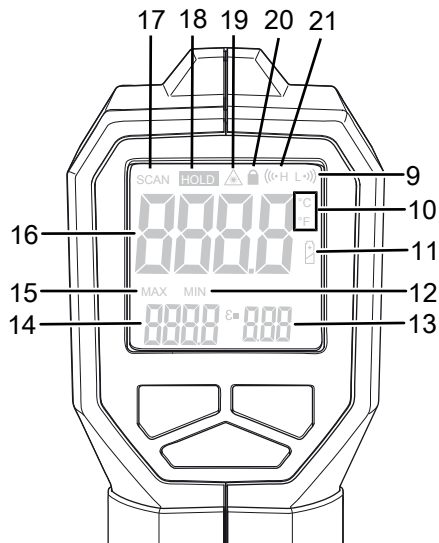

No.	Designation
9	Indication of the lower alarm threshold
10	Temperature unit indication
11	Battery status
12	MIN indication
13	Indication of the degree of emission
14	MAX MIN temperature display
15	MAX indication
16	Measurement value display
17	SCAN indication
18	HOLD indication
19	Laser indication
20	Indication for continuous measurement
21	Indication of the upper alarm threshold

Technical data

Parameter	Value
Model	BP21
Weight	185 g
Dimensions (H x W x D)	160 mm x 53 mm x 45.6 mm
Measuring range	-35 °C to 800 °C (-31 °F to 1472 °F)
Measuring range resolution	0.1 °C / °F
Laser output	< 1 mW (630–670 nm)
Laser	Class II, 630 to 670 nm, < 1 mW
Accuracy	± 2 °C (±4 °F) or ± 2.0 % of the measured value (the higher value applies)
Degree of emission	Adjustable
Distance to measuring spot diameter ratio	12:1
Smallest measuring spot	∅ 12.7 mm (distance 127 mm)
Spectral sensitivity	8 to 14 µm
Reaction time	< 1 s
Operating temperature	0 °C to 50 °C (32 °F to 122 °F)
Relative humidity during operation	Max. 80 % relative humidity
Storage conditions	-20 °C to 60 °C
Power supply	9 V battery
Switch-off	After approx. 8 seconds of non-use

Scope of delivery

- 1 x Pyrometer BP21
- 1 x 9 V battery
- 1 x Device bag
- 1 x Quick guide

Transport and storage

Note

If you store or transport the device improperly, the device may be damaged.
 Note the information regarding transport and storage of the device.

Transport

For transporting the device, use the bag included in the scope of delivery in order to protect the device from external influences.
 The manufacturer packed the device to the best of his abilities to protect it against transport damage.

Storage

When the device is not being used, observe the following storage conditions:

- dry and protected from frost and heat
- protected from dust and direct sunlight
- with a cover to protect it from invasive dust if necessary
- The storage temperature is the same as the range given in the Technical data chapter.
- Remove the batteries from the device.
- Preferably use the supplied device bag to store the device.

Operation

Inserting the battery

Note

Make sure that the surface of the device is dry and the device is switched off.

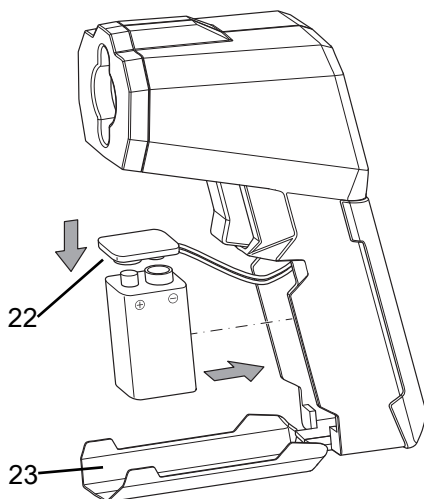

1. Open the battery compartment by folding open the cover (23) with your fingers.
2. Use the battery clip (22) to connect the new battery with correct polarity.
3. Insert the battery in the battery compartment.
4. Close the cover of the battery compartment.

Carrying out a measurement



Info

Please note that moving from a cold area to a warm area can lead to condensation forming on the device's circuit board. This physical and unavoidable effect can falsify the measurement. In this case, the display shows either no measured values or they are incorrect. Wait a few minutes until the device has become adjusted to the changed conditions before carrying out a measurement.

- Ensure that the surface to be measured is free of dust, dirt or similar substances.
 - To be able to gain exact measurement results on surfaces which reflect heavily, stick matt masking tape to the surface or apply matt black paint with a very high and known degree of emission.
 - Note the 12:1 ratio of the distance to the measuring spot size. For accurate measurements the measuring object should be at least twice as large as the measuring spot.
1. Point the device at the object to be measured.
 2. Press the measurement button (6).
 - ⇒ Hold onto the measurement button (6) if you want to perform a prolonged measurement.
 - ⇒ The device turns on and carries out a measurement. The SCAN indication (17) appears on the display.
 - ⇒ The current measured value is displayed in the measurement value display (16).
 3. Let go of the measurement button (6) again.
 - ⇒ The device stops measuring. HOLD (18) appears on the display. Depending on the setting of the device, either the maximum or minimum value of the last measurement cycle will be shown in addition.
 - ⇒ The device switches off after approx. 8 seconds.

Switching the laser pointer on or off

Ex works the laser pointer is switched off.



Danger

Please observe that with a switched-on laser the laser pointer will go on as soon as you press the measurement button (6) or activate continuous measurement.



Warning of laser radiation

Class 2 laser radiation.

Lasers of class 2 only radiate in the visible range and during continuous wave operation (lasting beam) no more than 1 milliwatt (mW) of output will be emitted. Looking directly into the laser beam for a longer period of time (more than 0.25 seconds) can cause damage to the retina.

Avoid looking directly into the laser beam. Never look into the laser beam using optical aides. Do not suppress the winking reflex when looking into the laser beam unintentionally. Never point the laser beam at people or animals.

1. Press the Laser button (4) when the device is in operation.
 - ⇒ The laser indication (19) appears on the display (1).
 - ⇒ The laser pointer is switched on.
2. Press the laser button (4) again to switch the laser pointer off.
 - ⇒ The laser indication (19) is no longer displayed.
 - ⇒ The laser pointer is switched off, memorising the selected settings.

Switching the display illumination on or off

The display illumination is switched off by default and can be switched on or off as needed by pressing the lamp button (2). For this purpose, the device must be in operation.

The device memorizes the selected setting when switching off.

Further setting options

1. By use of the Mode key (3) you can access the extended choice of settings. The alarm threshold and temperature unit can be selected here, for instance.
2. Enable the device file by pressing the measurement button (6). Press the Mode key (3) several times to reach the desired setting:

Number	Menu option	Description
1x	Setting the degree of emission	Further information regarding the degree of emission can be found in the chapter "Information about the device").
2x	Setting the temperature unit	The measured value can be displayed in °C or °F.
3x	Activating maximum or minimum value	According to the selection, either the highest or the lowest measured value will be displayed.
4x	Activating continuous measurement	The symbol for continuous measurement (20) flashes on the display. By pressing the laser button (4) (up) and the lamp button (2) (down), the continuous measurement function can be activated (ON) or deactivated (OFF). Adjust the settings as required and press the measurement button (6) to activate it. With activated continuous measurement you can adjust the degree of emission to changing grounds by means of the laser button (4) (up) and the lamp button (2) (down). On the other hand, it is no longer possible to switch the background illumination or the laser beam on and off. For this reason, select the corresponding setting before activating continuous measurement. By pressing the measurement button (6), continuous measurement can be deactivated again.
5x	Enabling/disabling the upper alarm threshold	Upon exceeding the selected upper alarm value, an acoustic alarm signal is emitted.
6x	Entering the upper alarm value	Here you can enter the value for the upper alarm threshold.
7x	Enabling/disabling the lower alarm threshold	Upon exceeding the selected lower alarm value, an acoustic alarm signal is emitted.
8x	Entering the lower alarm value	Here you can enter the value for the lower alarm threshold.

Example: Setting the degree of emission:

1. Press the Mode key (3) once.
 - ⇒ Extended setting mode will be started.
 - ⇒ The Degree of emission indication (13) flashes.
2. Adjust the degree of emission by increasing the value using the laser button (4) or by decreasing it using the lamp button (2).
 - ⇒ The value range is between 1.00 and 0.10.
3. Press the measurement button (6) to confirm the selected settings.
 - ⇒ The settings are saved and you will exit the extended setting mode.

Switching the device off

- With activated HOLD indication (18) the device switches off automatically after approx. 8 seconds.
- By pressing the measurement button (6), continuous measurement can be deactivated. The device switches over to the HOLD (18) indication and will switch off automatically after approx. 8 seconds.

Maintenance and repair

Battery change

A battery change is required when a battery indication (11) lights up on the display (1) or the device can no longer be switched on. See chapter Operation.

Cleaning

Clean the device with a soft, damp and lint-free cloth. Make sure that no moisture enters the housing. Do not use any sprays, solvents, alcohol-based cleaning agents or abrasive cleaners, but only clean water to moisten the cloth.

Repair

Do not modify the device or install any spare parts. For repairs or device testing, contact the manufacturer.

Errors and faults

The device has been checked for proper functioning several times during production. If malfunctions occur nonetheless, check the device according to the following list.

The device does not switch on:

- Check the charging status of the battery. Change the battery, if required (see chapter Inserting the battery).
- Make sure that the battery is properly positioned. Check the polarity is correct.

Disposal



The icon with the crossed-out waste bin on waste electrical or electronic equipment stipulates that this equipment must not be disposed of with the household waste at the end of its life. You will find collection points for free return of waste electrical and electronic equipment in your vicinity. The addresses can be obtained from your municipality or local administration. For further return options provided by us please refer to our website <https://de.trotec.com/shop/>.

The separate collection of waste electrical and electronic equipment aims to enable the re-use, recycling and other forms of recovery of waste equipment as well as to prevent negative effects for the environment and human health caused by the disposal of hazardous substances potentially contained in the equipment.



In the European Union, batteries and accumulators must not be treated as domestic waste, but must be disposed of professionally in accordance with Directive 2006/66/EC of the European Parliament and of the Council of 6 September 2006 on batteries and accumulators. Please dispose of batteries and accumulators according to the relevant legal requirements.

PROMAT (HK) Limited 寶時 (香港) 有限公司

☎ : 2661 2392 📞 : 5196 8860 ✉ : info@promat.hk 🌐 : http://www.promat.hk

