



# miniweigher plus



This small and compact mini crane weigher scale will suit most lifting applications. Available in capacities from 100kg to 5t. Worldwide, it's our most popular product and has been manufactured since 1987. The MiniWeigher Plus crane scale offers robust construction, high accuracy, compact size and extreme portability.

Utilised by utility companies on every continent, the MiniWeigher Plus crane scale is quite often mounted between a winch and a tripod, allowing the load monitoring and safe lowering and raising of equipment and personnel, and has proven itself to be an indispensable tool for underground sewer, water, gas, and utility vault access.

The MiniWeigher Plus features full function push button controls for tare, choice of units (lbs, kg, kN and tonnes), peak hold, preset tare, audible set-point alarm and an overload counter.

Straightpoint's advanced microprocessor based electronics provide the MiniWeigher Plus with high speed read rates (500/sec), extreme resistance to industrial level noise and unprecedented stability. This high stability allows 5,000 + divisions and the highest standard resolution of any compact digital crane scale on the market today. The unit also features a RS-485 serial output providing added functionality and versatility.

In all, the lightweight design, corrosion resistant finish, advanced electronics and full feature display have made the MiniWeigher Plus crane scale the only choice when looking for a compact and lightweight light capacity crane scale.

## Features and benefits:

- Large LCD Display
- High Accuracy
- Selectable Units
- High Resolution
- Compact Size
- Tare
- Preset Tare
- Lightweight
- Overload Counter
- Audible Set Point Alarm
- RS-485 Serial Output
- Corrosion Resistant Finish

# metric specifications

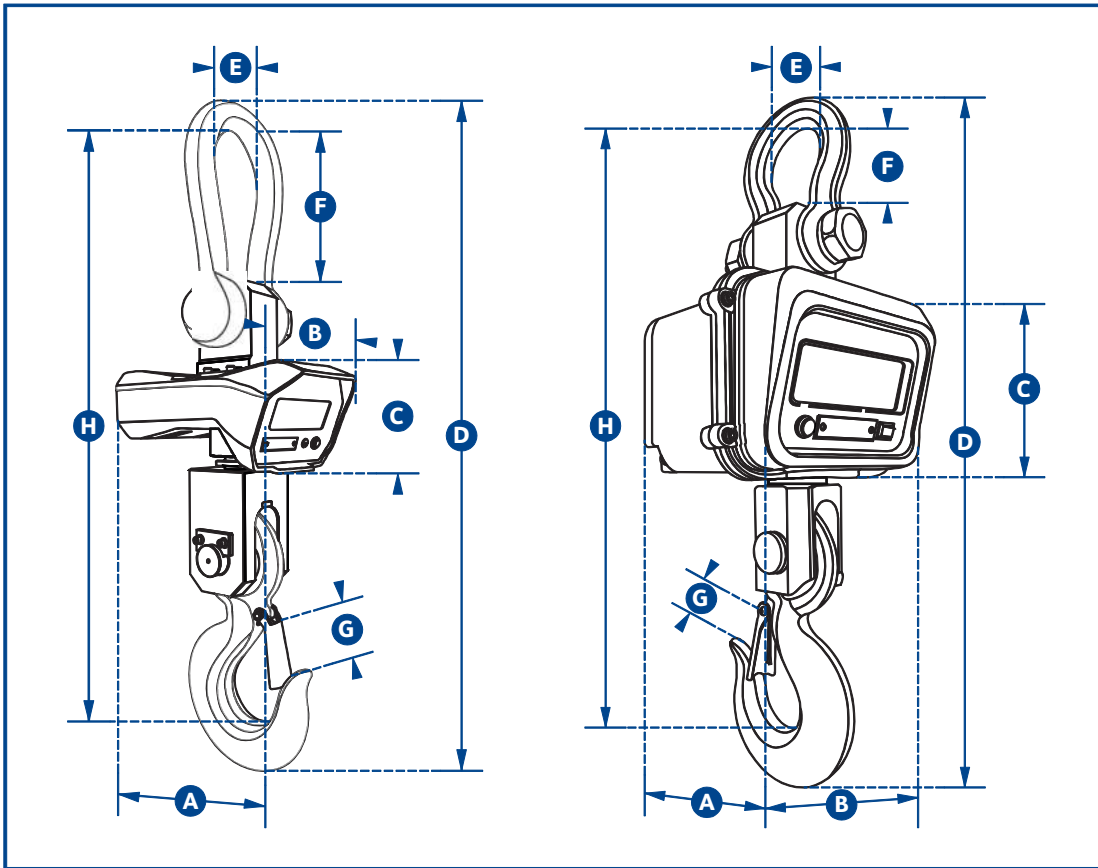

# jumboweigher

Part Number	JW5T	JW10T	JW20T
Capacity	5000kg	10,000kg	20,000kg
Resolution	2kg	5kg	10kg
Units	kg		
Weight	18kg	29kg	75kg
Safety Factor	5:1		
Battery Type	Internal rechargeable		
Battery Life	20 hours		
Operating Temp	-10°C to +40°C		
Accuracy	±0.3% of applied load		
Display Type	30mm LED		
Protection	IP54		
Dimension A	195	195	355
Dimension B	225	255	230
Dimension C	180	180	165
Dimension D	715	780	1115
Dimension E	72	90	140
Dimension F	90	110	230
Dimension G	36	50	70
Dimension H	595	660	980



**PROMAT (HK) Limited 寶時(香港)有限公司**  
 901 New Trend Center, 704 Prince Edward Road East, SPK, Kln, HK  
 香港九龍新蒲崗太子道東704號新時代商業中心901室  
 TEL: (+852) 2661 2392 FAX: (+852) 2661 2086  
 Email: sales@promat.hk http://www.promat.hk

