

BG30

EN

OPERATING MANUAL
GAS DETECTOR



PROMAT

TROTEC

Table of contents

Notes regarding the operating manual..... 2

Safety 2

Information about the device..... 4

Transport and storage..... 4

Operation 5

Maintenance and repair 6

Errors and faults..... 7

Disposal 7

Notes regarding the operating manual

Symbols

 **Warning of electrical voltage**
 This symbol indicates dangers to the life and health of persons due to electrical voltage.

 **Warning**
 This signal word indicates a hazard with an average risk level which, if not avoided, can result in serious injury or death.

 **Caution**
 This signal word indicates a hazard with a low risk level which, if not avoided, can result in minor or moderate injury.

Note
 This signal word indicates important information (e.g. material damage), but does not indicate hazards.

 **Info**
 Information marked with this symbol helps you to carry out your tasks quickly and safely.

 **Follow the manual**
 Information marked with this symbol indicates that the operating manual must be observed.

You can download the current version of the operating manual and the EU declaration of conformity via the following link:



BG 30



<https://hub.trotec.com/?id=44683>

Safety

Read this manual carefully before starting or using the device. Always store the manual in the immediate vicinity of the device or its site of use.

-  **Warning**
Read all safety warnings and all instructions. Failure to follow the warnings and instructions may result in electric shock, fire and/or serious injury. **Save all warnings and instructions for future reference.**
- This appliance can be used by children aged from 8 years and above and persons with reduced physical, sensory or mental capabilities or lack of experience and knowledge if they have been given supervision or instruction concerning use of the appliance in a safe way and understand the hazards involved. Children shall not play with the appliance. Cleaning and user maintenance shall not be made by children without supervision.
- Do not use the device in potentially explosive rooms or areas and do not install it there.
 - Do not use the device in aggressive atmosphere.
 - Do not immerse the device in water. Do not allow liquids to penetrate into the device.
 - The device may only be used in dry surroundings and must not be used in the rain or at a relative humidity exceeding the operating conditions.
 - Protect the device from permanent direct sunlight.
 - Do not remove any safety signs, stickers or labels from the device. Keep all safety signs, stickers and labels in legible condition.
 - Do not open the device.
 - Observe the storage and operating conditions as given in the Technical data chapter.
 - High concentrations of highly flammable gases can cause explosions, fire, suffocation and other hazards. Please obtain information on the gas you are working with and take the appropriate precautions.

- Calibrate the device in an environment that is free from gases affecting the measurement.

Intended use

Only use the device to detect the following flammable or interfering gases: natural gas, methane, ethane, propane, butane, acetone, alcohol, ammonia, water vapour, petrol, turbine fuel, hydrogen sulphide, smoke, industrial solvents, paint thinners, naphtha.

Only use the device e.g. to detect gas leaks on pipelines or fittings.

The device is able to detect gas concentrations of 10 % LEL (Lower Explosion Limit).

The device is only intended for private, non-commercial use in interior spaces.

To use the device for its intended use, only use accessories and spare parts which have been approved by Trotec.

Improper use

Do not use the device in hazardous areas or in any areas where an explosive gas/air mixture is likely to prevail.

The device is not intended for professional/commercial use.

Do not use the device as monitoring device for your personal safety. The device is no protective equipment.

Do not use the device for measurements in liquids and at live parts. Trotec accepts no liability for damages resulting from improper use. In such a case, any warranty claims will be voided. Any unauthorised modifications, alterations or structural changes to the device are forbidden.

Personnel qualifications

People who use this device must:

- have read and understood the operating manual, especially the Safety chapter.

Residual risks



Warning of electrical voltage

There is a risk of a short-circuit due to liquids penetrating the housing!

Do not immerse the device and the accessories in water. Make sure that no water or other liquids can enter the housing.



Warning of electrical voltage

Work on the electrical components must only be carried out by an authorised specialist company!



Warning of explosive substances

There is a danger of explosion due to sparking. Switch on the measuring device in an atmosphere that is free from combustible gas. The device calibrates itself automatically after switch-on. If combustible gases are already present in the environment, any further measuring results can be distorted and combustible gases may remain undetected.



Warning

High concentrations of combustible gases cause a risk of explosion, fire and suffocation.

Make yourself familiar with the safety data sheet regarding the characteristics of the gas to be detected and take the necessary precautions.



Warning

Risk of suffocation!

Do not leave the packaging lying around. Children may use it as a dangerous toy.



Warning

The device is not a toy and does not belong in the hands of children.



Warning

Dangers can occur at the device when it is used by untrained people in an unprofessional or improper way! Observe the personnel qualifications!



Caution

Keep a sufficient distance from heat sources.

Note

To prevent damages to the device, do not expose it to extreme temperatures, extreme humidity or moisture.

Note

Do not use abrasive cleaners or solvents to clean the device.

Information about the device

Device description

The device BG 30 detects the following combustible and/or unwanted gases: natural gas, methane, ethane, propane, butane, acetone, alcohol, ammonia, water vapour, petrol, turbine fuel, hydrogen sulphide, smoke, industrial solvents, paint thinners, naphtha.

The measuring device is able to detect gas concentrations of as low as 10 % LEL (Lower Explosion Limit) and warns the user via both a visual and an acoustic alarm. The flexible gooseneck allows you to easily reach poorly accessible locations.

Definition of LEL

- LEL = Lower Explosion Limit

The LEL of a combustible gas is the minimum concentration of this gas at which the gas can start to burn when exposed to a source of ignition (e.g. a match). At concentrations below the LEL, the gas does not burn. Gas detectors for combustible gases are generally calibrated for 0 – 100 % LEL.

Device depiction

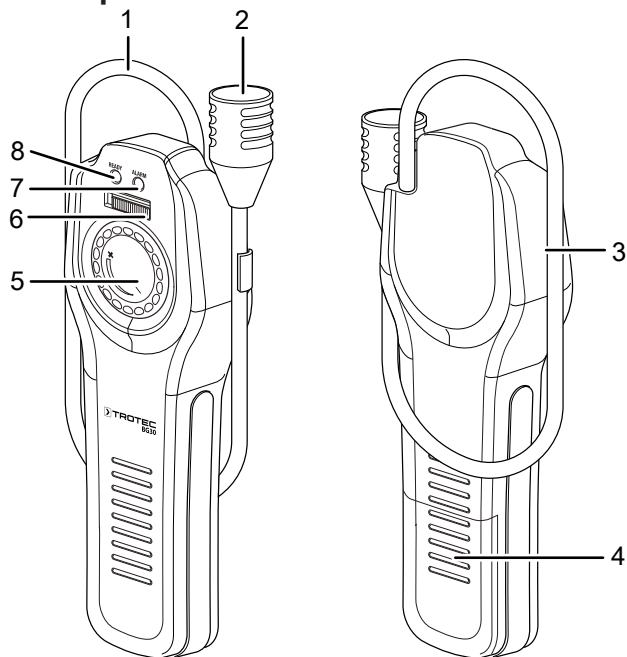

No.	Designation
1	Gooseneck probe
2	Sensor
3	Connection for headphones
4	Cover of the battery compartment
5	Sensitivity control
6	On/off switch
7	Alarm LED
8	Operation indicator LED

Technical data

Parameter	Value
Model	BG 30
Weight	520 g
Dimensions (length x width x height)	221 x 24 x 72 mm
Standard calibration	Methane
Accuracy	±50 ppm
Alarm threshold	min. 10 % LEL max. 40 % LEL for methane
Warm-up time	Approx. 60 s
Response time	< 2 sec at up to 40 % LEL
Power supply	3 x 1.5 V batteries, type C
Operating temperature	0 °C to 50 °C (32 °F to 122 °F)
Storage temperature	-30 °C to 60 °C (-22 °F to 140 °F)
Operating humidity	0 % RH to 90 % RH (non-condensing)

Scope of delivery

- 1 x Device BG 30
- 3 x 1.5 V batteries, type C
- 1 x Bag / holster
- 1 x Quick guide

Transport and storage

Note

If you store or transport the device improperly, the device may be damaged. Note the information regarding transport and storage of the device.

Transport

For transporting the device, use the bag included in the scope of delivery in order to protect the device from external influences.

Storage

When the device is not being used, observe the following storage conditions:

- dry and protected from frost and heat
- protected from dust and direct sunlight
- with a cover to protect it from invasive dust if necessary
- The storage temperature is the same as the range given in the Technical data chapter.
- Remove the batteries from the device.

Operation

Inserting the batteries

- Insert the supplied batteries before first use.

Note

Make sure that the surface of the device is dry and the device is switched off.

1. Remove the battery compartment cover (4) from the battery compartment.

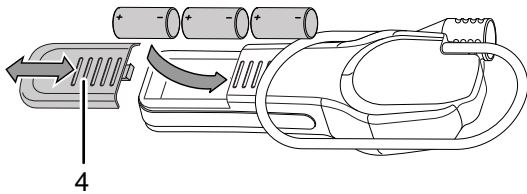

2. Insert three 1.5 V batteries of type C with correct polarity into the battery compartment (+/-).
3. Close the battery compartment by sliding the battery compartment cover over the battery compartment.

Attaching the warning sign

Prior to initial start-up, check whether the warning sign at the rear of the device is in your local language, if not, paste the proper one over it. The warning sign is supplied along with the device in several languages. Please proceed as follows to attach the warning sign to the rear of the device:

1. Remove the label in your local language from the supplied film.
2. Affix the label in the intended position at the rear of the device.

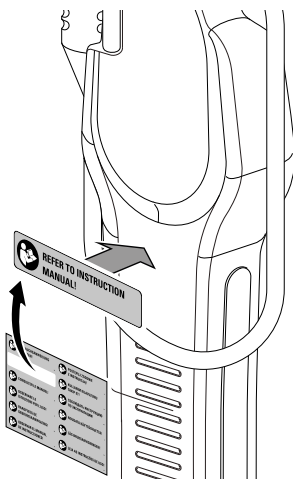

Switch-on/warm-up phase

Note

Chemical cleaning agents often contain solvents and alcohols to which the appliance may react. It is not possible to avoid this cross-sensitivity which can lead to misleading results. For this reason, remove chemical cleaners from the detection area of the device prior to performing a leak detection.

1. Go to a place with a low CO concentration (e.g. fresh air).
2. Turn the sensitivity control (5) counter-clockwise in the direction of the minus symbol in order to set a minimum sensitivity value.
3. Slide the on/off switch (6) to the right to switch the device on.

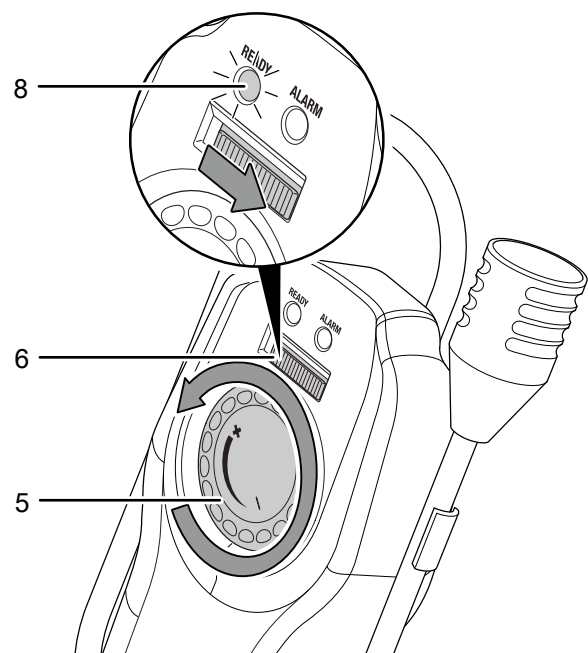

- ⇒ The operation indicator LED (8) lights up.
- ⇒ The warm-up phase of the device is started. During the warm-up phase (approx. 60 seconds) the device automatically calibrates itself the device may emit warning signals. After the warm-up phase the warning signal rate decreases until the signal finally stops completely.
- ⇒ The device is ready for operation.

Gas leak detection

1. Adjust the sensitivity level using the sensitivity control (5) until you hear a slow, steady ticking sound.
2. Move the sensor towards the suspected leak.
 - ⇒ If a higher gas concentration is detected, the ticking sound frequency increases.
 - ⇒ Once a gas concentration of approximately 10 % LEL of methane is reached, the alarm LED (7) flashes and you hear a warning sound. The volume of the alarm sound increases with an increasing gas concentration.

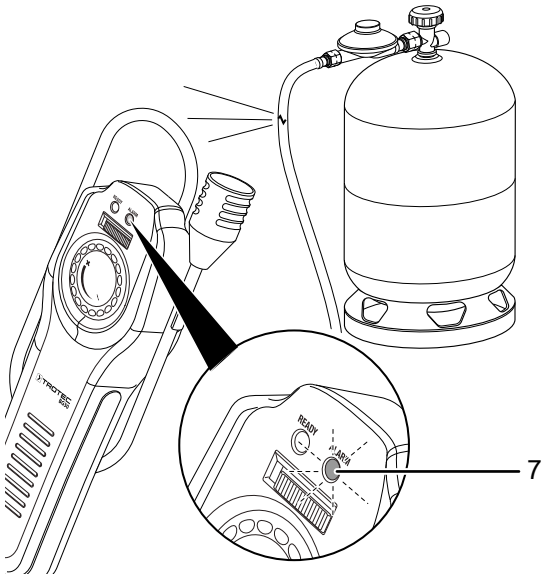

Info

In areas with high gas concentrations, the ticking frequency can be readjusted by turning the sensitivity control (5) counter-clockwise which will make it easier to find the leak.

Connecting the headphones

Headphones can be connected to the device if you are working in noisy environments. The integrated speaker is no longer in operation once headphones are connected. The ticking and warning signals thus do not disturb anyone in your environment.

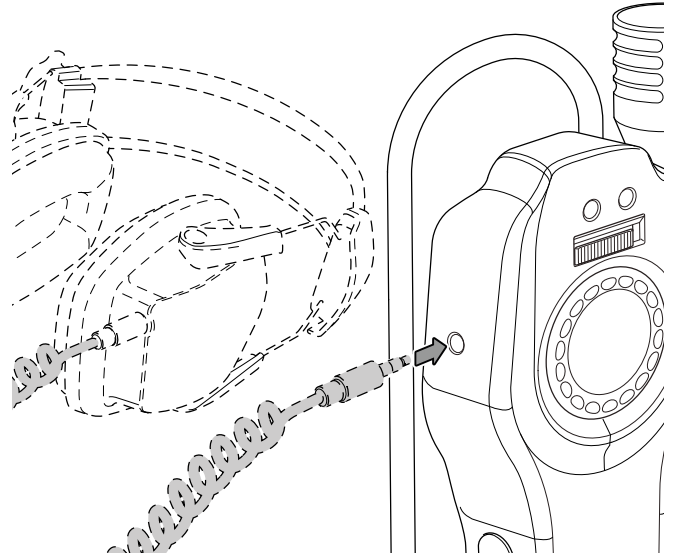

Note

The warning signals may be amplified by headphones and could therefore be very loud.

Switch-off

1. Slide the on/off switch (6) to the left to switch the device off.
 - ⇒ The operation indicator LED (8) goes out.

Maintenance and repair

Battery change

The batteries must be replaced in the following cases:

- The operation indicator LED (8) is no longer illuminated or flashes.
- Even after adjusting the sensitivity level on the sensitivity control (5), the device still does not emit any acoustic signals after approx. 2 minutes.

For information on changing the battery refer to the chapter Operation.

Cleaning

Clean the device with a soft, damp and lint-free cloth. Make sure that no moisture enters the housing. Do not use any sprays, solvents, alcohol-based cleaning agents or abrasive cleaners, but only clean water to moisten the cloth.

Repair

Do not modify the device or install any spare parts. For repairs or device testing, contact the manufacturer.

Errors and faults

The device has been checked for proper functioning several times during production. If malfunctions occur nonetheless, check the device according to the following list.

Fault	Cause	Remedy
The device can no longer be switched on.	The batteries are empty.	Insert new batteries (see chapter Operation).
The operation indicator LED is no longer illuminated or flashes.	The battery voltage is too low.	
Even approx. 2 minutes after having adjusted the sensitivity level, the device still does not emit any acoustic signals.		
The device emits a continuous acoustic signal despite the lowest sensitivity is being set (sensitivity control completely turned counter-clockwise).	The gas concentration is very high.	Leave the area immediately! Take appropriate emergency measures such as turning off the gas supply to protect yourself and others.
The device emits a continuous acoustic signal even in a gas-free environment and after having inserted a new battery.		Please contact the customer service.

Disposal



The icon with the crossed-out waste bin on waste electrical or electronic equipment stipulates that this equipment must not be disposed of with the household waste at the end of its life. You will find collection points for free return of waste electrical and electronic equipment in your vicinity. The addresses can be obtained from your municipality or local administration. For further return options provided by us please refer to our website <https://de.trotec.com/shop/>.

The separate collection of waste electrical and electronic equipment aims to enable the re-use, recycling and other forms of recovery of waste equipment as well as to prevent negative effects for the environment and human health caused by the disposal of hazardous substances potentially contained in the equipment.



In the European Union, batteries and accumulators must not be treated as domestic waste, but must be disposed of professionally in accordance with Directive 2006/66/EC of the European Parliament and of the Council of 6 September 2006 on batteries and accumulators. Please dispose of batteries and accumulators according to the relevant legal requirements.

PROMAT (HK) Limited 寶時 (香港) 有限公司

☎ : 2661 2392 📞 : 5196 8860 ✉ : info@promat.hk 🌐 : http://www.promat.hk

